

Simultaneous measurements of viscosity and density in solutions undergoing change

(magnetic suspension/torque measurements/ribonuclease random coils)

J. W. BEAMS*† AND D. W. KUPKE‡

* Department of Physics and † Department of Biochemistry, The University of Virginia, Charlottesville, Virginia 22903

Contributed by Jesse W. Beams, July 29, 1977

ABSTRACT The magnetic suspension densimeter-viscometer has been modified so that the variations of viscosity and density in solutions undergoing change are determined continuously as a function of time. The changes in values for both of these properties are also obtained when solutions of varying composition are passed through the sample cell (<0.5 ml). The new method measures the torque on the magnetically suspended buoy which is held stationary in a stable velocity gradient; this procedure also facilitates the measurement of the density with greater accuracy. Preliminary results relating to the conformation changes of ribonuclease A in the presence of guanidinium chloride and a disulfide cleaving agent are presented.

In many cases it is desirable to know accurately the viscosity and density of solutions that are not at equilibrium and in which chemical or physical changes, or both, are occurring. Often these changes are small and the simultaneous determination of these two properties becomes important as a function of time as well as in decreasing the amount of effort and material expended. The magnetic suspension densimeter-viscometer described previously (1-3) has been found useful and reliable for determining densities and viscosities concurrently on small samples (0.2 ml) that are at equilibrium or in which the viscosity is changing slowly. Although the time required to obtain an accurate measurement of the density (1 part in 10^5 or better) was only a few seconds, it usually required 1 or more minutes to determine the viscosity (1 part in 10^3 - 10^4) when small shearing stresses (10^{-3} dyne cm^{-2}) were used.

In the present work, we have modified the magnetic suspension densimeter-viscometer so that the time required to make accurate, simultaneous measurements of both the density and viscosity is significantly reduced and the variation in viscosity is determined at constant rates of shearing. The essential difference between the old and new designs is that in the former the cylindrical glass chamber that contained the solution was stationary and the magnetically suspended coaxial buoy was slowly rotated, whereas in the newer design the cylinder is slowly rotated at constant speed and the buoy is held stationary. This change makes it possible to measure electrically the torque on the buoy promptly. Because the torque is proportional to the square of the viscosity at a selected rate of shearing, the viscosity, as well as the density, is determined continuously.

EXPERIMENTAL

Fig. 1 is a diagram (not to scale) of the improved instrument. The buoy B is magnetically suspended in the solution which completely fills the glass cell C (currently a precision-bore cylinder about 2×0.4 cm with a viewing length of about 1 cm;

when filled, C contains about 0.3 ml, depending upon the size of the buoy and of the solution distributor T_3). C is slowly rotated around the vertical axis A_1 - A_6 by a 0.5 horsepower (3.7×10^2 W) clock-type constant-speed motor driven by the 60-cycle 110-V source. Different motors have been used (usually between 0.25 and 2 rpm, depending upon the shear stresses desired). The vertical axis of C accurately coincides with A_1 - A_6 . The drive shaft consists of a stainless steel rod, A_6 - A_4 , that passes through the guide bearing A_5 and is fastened to a stainless steel tube at A_4 . This tube passes through the liquid-tight gland G_2 and connects with a stainless steel hypodermic needle between G_2 and A_3 . The needle passes through the liquid-tight gland G_2 and is accurately anchored and centered in the lower, hard plastic, end cap of C. This needle also supports and drives the rotatable cell C. The top guide and seal bearing at A_2 consists of a thin-walled, hard plastic tube that rotates in a low-friction Teflon bushing. The inner diameter of the plastic tube is slightly larger than the outer diameter of the buoy so that the latter can be inserted and removed from C (as well as for other purposes, such as the introduction of thermistor probes). A smaller diameter plastic tube fits loosely inside this tube, which both reduces the volume and limits the height of the buoy during the magnetic suspension procedure. Another hypodermic needle is fastened securely into the top of the rotatable plastic tube and then passes through a liquid-tight gland G_1 . Small holes in this rotatable needle allow liquid to flow out at A_1 . The glands G_1 and G_2 are sealed by O rings as shown and are carefully lubricated with silicone or other nonreacting greases. These glands ride on Teflon thrust bearings T_1 and T_2 and are made as friction-free as possible. Both glands are anchored to the frame of the apparatus.

In order to fill C, the solution is slowly forced into G_2 by a gas-tight syringe, usually while C is turning. From G_2 the solution enters the tubular shaft through one or more small radial holes and then passes up into the chamber of C. Upon entering C, the solution is spread by a series of channels in the Teflon spacer T_3 which is anchored to the bottom of C. After C is filled, the solution passes up and out through G_1 into a collector via A_1 . Clearly, the flow may be made continuous or may be stopped as the cell continues to rotate; for highest accuracy in the measurements and for better temperature control, the flow is stopped. C is surrounded by a cylindrical glass chamber through which water at constant temperature is circulated. The water temperature is monitored by thermometers and thermistors. The motor A_6 is supported on a vertically adjustable table jack (not shown) about 75 cm below C. This distance reduces the small magnetic effects of the motor and allows C to be

The costs of publication of this article were defrayed in part by the payment of page charges. This article must therefore be hereby marked "advertisement" in accordance with 18 U.S.C. §1734 solely to indicate this fact.

Abbreviations; RNase, ribonuclease A (bovine pancreatic); GdmCl, guanidinium chloride.

† Dr. J. W. Beams died on July 23, 1977, just after this manuscript was completed.

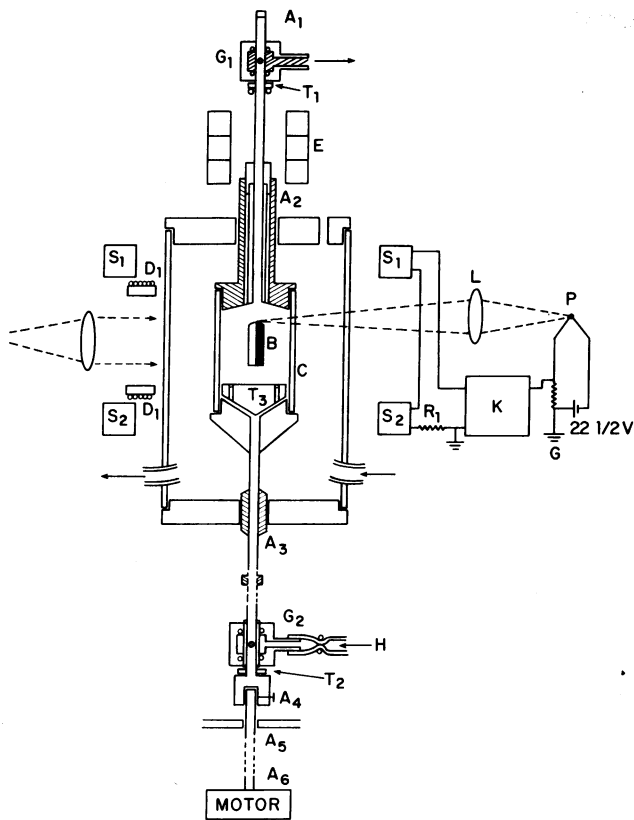

FIG. 1. Diagram of the modified visco-densimeter.

moved up and down over small distances; the latter flexibility is a convenience for bringing B into support.

Several methods for supporting the buoy magnetically for the density application have been described (4) and a more recent list of these references is now available (5). Fig. 1 shows a simple, although not the best available, support method for this type of experiment. It consists of a number of hard, strong, ring magnets E mounted above A₂ with their resultant magnetic moment coaxial with the vertical axis A₂-A₃. The vertical distance between E and B is adjustable and is usually such that B is not quite supported by E. The current through the derivative coils S₁ and S₂ is regulated by the optically sensed servo system to support B magnetically. When the buoy is properly positioned with respect to these derivative coils, the current through them is directly proportional to the density of the buoyant medium when the major supporting field is constant (6). After calibration with solutions of known density, the density of any

other solution in C is obtained routinely to better than 1 part in 10⁵ from the potential drop across a standard, calibrated, 1-ohm resistor R₁.

The buoy, which contains electrically conducting material, is slowly rotated by a rapidly rotating horizontal magnetic field produced by a 10⁴-Hz current through two pairs of identical, symmetrically spaced drive coils (100 turns each of AGW no. 22 insulated copper); one of these coils is shown at D₁ in Fig. 1 (compare Fig. 2). The inner diameter of the coils is 1 cm so that the buoy can be viewed through each of the coils.

The drive circuit is shown in Fig. 2. A 10⁴-Hz signal is generated by a piezoelectric crystal-controlled circuit. This signal passes through a valve type circuit that is regulated by a signal, the magnitude of which is determined by the angular position of the buoy around its axis. The surface of B is half light and half black, as shown in Fig. 1, so that as B rotates around its vertical axis the intensity of the scattered light from B when focused on the photodiode P (Figs. 1 and 2) produces a signal that regulates the magnitude of the 10⁴-Hz signal from the drive circuit. This signal is passed through a phase-splitting bridge Br. The two signals, which differ by approximately 90°, each actuates a power amplifier PA which in turn drives the pairs of drive coils D₁ and D₂. The two amplifiers PA are identical, but it was convenient to adjust their phases with an oscilloscope. When once adjusted, they were found not to change. It is, of course, well known that the torque on a particular buoy is directly proportional to the square of the electromotive force induced in a pick-up coil (f in Fig. 2) located in the rotating magnetic field.

Great care must be used in the construction of the buoy B. Theoretically, the density of B should be approximately equal to that of the solution for the most accurate measurements of the density. On the other hand, when density gradient coils, such as S₁ and S₂ (Fig. 1), are used in the support system, the density of B can be considerably greater or less than that of the solution without serious loss in accuracy (6). The size of B, as well as that of C, is determined largely by the amount of solution available and the length of gap desired between B and the inner surface of C. Buoys 1-3 mm in diameter and 5-10 mm long have been used with the cell C. When the buoy possesses a permanent magnetic moment, the direction of the moment must coincide accurately with the mechanical axis of the cylindrical buoy. B is usually a small-diameter rod of ferromagnetic material surrounded by a snugly fitting plastic or light nonmagnetic cylinder; on occasions, the ferromagnetic rod is simply dipped into a solution of dissolved plastic (e.g., Plexiglas, glyptal, etc.) and allowed to dry. India ink is painted on roughly one-half of the cylindrical surfaces longitudinally as shown in

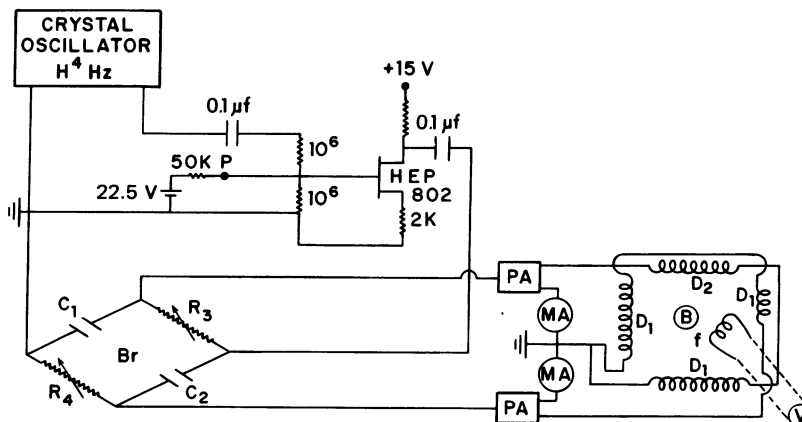

FIG. 2. Diagram of drive circuit for measuring the torque required to hold buoy stationary in response to viscosity changes.

Fig. 1 and is then covered by a film of clear glyptal. It has been found that annealed HyMu-80 (a permalloy from Carpenter Steel Co.) is a satisfactory material for the soft ferromagnetic metal (1-3) and a Cunif permanent magnet rod has been used successfully in these studies for the harder magnetic material. Both metals are machinable and are electrically conducting. With the soft material, the magnetic moment is induced and is automatically in the proper direction. The permanent moment in the harder material, however, must be carefully aligned. It was found particularly difficult to align the permanent moment of very hard ceramic magnetic material with the mechanical axis. Also, such buoys require electrically conducting material to be added for drive purposes. In some cases when the magnetic field emanating from E is relatively small at B and the permanent moment of B is large, it is helpful to compensate for the horizontal component of the earth's magnetic field by proper spacing of the ring magnets or by introducing Helmholtz coils.

The buoy is first supported magnetically in water while C is rotating. If B is observed to rotate around the vertical axis with the same uniform speed (at all orientations), the magnetic moment of B is satisfactorily positioned. The power to the drive system (Fig. 2) is next turned on while C and B are rotating. B immediately locks into a definite orientation and remains stationary as C continues to turn. The value of the electromotive force across f will then remain as constant as the rate of rotation of C, provided that the system is properly adjusted and aligned. After calibration with solutions of known density and viscosity (e.g., aqueous sucrose), measurements of the potential drop across R_1 (Fig. 1) and the square of the electromotive force across f are convertible into the respective values of these two properties for unknown solutions. For the most precise values, the readings are taken directly from the meters as a function of time, but it is convenient also to display these signals on a strip-chart recorder or an oscilloscope. Even with precision-bore Pyrex glass tubes for C, there are small variations in the refractive index. When photoelectric sensors are used as in Figs. 1 and 2, variations in the measured signals are observed with a period equal to that of the rotation of C. Because the period is known, the effect can be corrected for without serious loss of accuracy.

RESULTS

Fig. 3 *upper* shows the linear character of a typical calibration curve for the potential drop across R_1 versus the density of aqueous sucrose solutions. Fig. 3 *lower* is a plot of the relative viscosities of these solutions as determined by the instrument versus the known values. These curves are linear to the extent of the uncertainty with which the values of these properties of aqueous sucrose are known.

For the purpose of illustrating an application of this method, the change in specific viscosity with time after the addition of a disulfide cleaving agent to solutions of bovine pancreatic ribonuclease A (RNase) in denaturing medium was studied. In these experiments the RNase (P-L Biochemicals Inc., type 0330) was deionized and analyzed as described (7). The concentrated and deionized protein in water was freshly mixed with various weights of the denaturing agent, guanidinium chloride (GdmCl) [ultrapure grade, Schwarz/Mann, (7)]. A small amount (e.g., 0.2-7 μ l/ml) of the sulfhydryl agent, 2-mercaptoethanol, was mixed with the appropriate test solution via a gas-tight syringe and the mixture was immediately inserted into the instrument without resupporting the buoy or disturbing the rotation of the cell. Readings of the torque and density voltages were recorded prior to and during the filling procedure (15-30

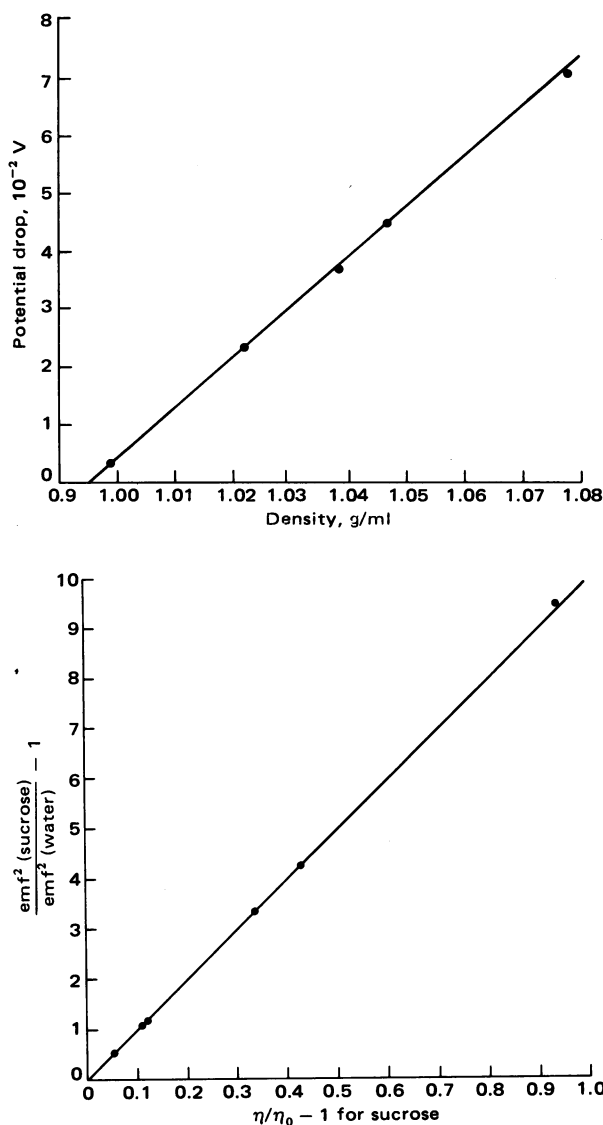

FIG. 3. (*Upper*) Potential drop across standard resistor R_1 versus aqueous sucrose solutions of known densities (20°). (*Lower*) Specific viscosity of aqueous sucrose solutions relative to water (20°) from measurements of the torque on the buoy versus known values. Electromotive force induced in f (Fig. 2) is denoted by emf which is squared for evaluating the relative viscosity.

sec) as the test solution containing no mercaptoethanol was pushed out. It is well known that the viscosity of protein solutions increases significantly in the presence of sulfhydryl agents, especially when the solvent medium contains a denaturant (cf. ref. 2 and references therein); the protein apparently adopts a random-coil-like conformation after the disulfide-bond restraints are removed.

With RNase, little or no increase in viscosity was observed below 2 M GdmCl during the test period (1-2 hr), whereas above this concentration the reaction proceeded too rapidly to permit observation of detail under our usual conditions of 2-10 mol of mercaptoethanol per mol of disulfide bond. Upon reducing the molar ratio to less than 1 mol of mercaptoethanol per mol of disulfide bond (above 2 M GdmCl), an unusual viscosity-time profile was repeatedly observed; the bizarre character persisted for an hour or more after a maximal viscosity had been achieved. In Fig. 4 are shown two examples at a common molality of RNase (0.002) in 3 and 6 M GdmCl (the

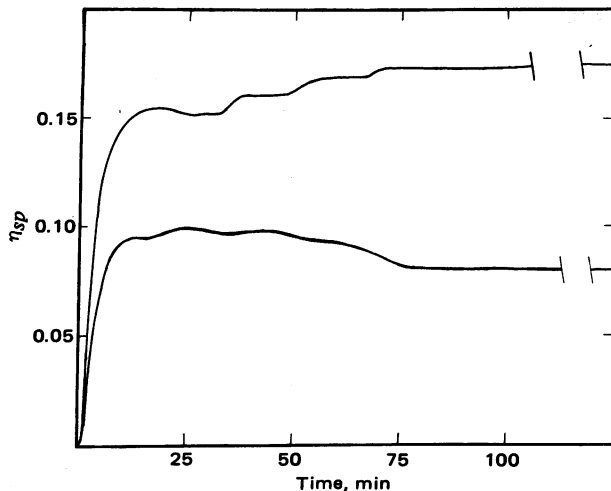

FIG. 4. Specific viscosity versus time after the addition of $0.2 \mu\text{l}$ of 2-mercaptoethanol per ml of the test solution containing 0.002 molal RNase (19.5°). Upper curve, 3 M GdmCl; lower curve, 6 M GdmCl. The curves are drawn to reflect the average of the digital values of the torque at 15-sec intervals; this was somewhat more accurate than the analog display used. The mixing and the insertion of the reacting solution which forced out the reference test solution required about 1 min as indicated by the small lag near the origin. The rate of shearing in these experiments was 0.209 sec^{-1} .

fraction of RNase molecules in the denatured form is thought to be about 0.5 in 3 M and about 1.0 in >4 M GdmCl). Owing to the molal concentration scale used here, about 1.5 mol and 2 mol of disulfide bond per mol of mercaptoethanol (four S—S bonds per RNase) were present in the 3 and 6 M GdmCl experiments, respectively. The unsmooth character of the curves

was reproducible. In particular, the viscosity in the 3 M GdmCl medium continued to increase in a somewhat stepwise manner toward a stable plateau, whereas in 6 M GdmCl the viscosity decreased toward a stable plateau after reaching an initial maximal value.

The overall instability of the instrument, as judged from long-term oscillations with solvent mixtures and with test solutions containing no mercaptoethanol, yielded an uncertainty in the specific viscosity that was clearly less than ± 0.002 —except when the electric current supply fluctuated substantially. The density changes for this reaction are very small (cf. ref. 2) and are not included. In general, the density was observed to increase linearly (about 10^{-4} g/ml) as the reaction proceeded toward the stable plateaus, in agreement with the direct density experiments upon rupturing disulfide bridges in GdmCl (7).

We are much indebted to Mr. W. Frewer for the precise fabrications and to Mr. T. E. Dorrier for the preparations, analytical work, and some of the construction. We also thank Drs. G. T. Gillies and M. G. Hodgins for consultations on design aspects. This work was supported by Grants CHE-76-09265 and BMS-75-01599 from the National Science Foundation and by Grant GM-19682 from the National Institutes of Health.

1. Hodgins, M. G. & Beams, J. W. (1971) *Rev. Sci. Instrum.* **42**, 1455–1457.
2. Kupke, D. W., Hodgins, M. G. & Beams, J. W. (1972) *Proc. Natl. Acad. Sci. USA* **69**, 2258–2262.
3. Hodgins, M. G., Hodgins, O. C., Kupke, D. W. & Beams, J. W. (1975) *Proc. Natl. Acad. Sci. USA* **72**, 3501–3504.
4. Kupke, D. W. & Beams, J. W. (1972) *Methods Enzymol.* **26**, 74–107.
5. Haynes, W. M. (1977), *Rev. Sci. Instrum.* **48**, 39–41.
6. Beams, J. W. (1969) *Rev. Sci. Instrum.* **40**, 167–168.
7. Crouch, T. H. & Kupke, D. W. (1977) *Biochemistry* **16**, 2586–2593.